



PVR ALUMINIUM & GLASS

SANIYA HEMAD

PLOT NO. - 9, VRUNDA EMBRO PARK,
NR. ANTHEM CIRCLE TO KOSMADA RING ROAD,
SANIYA HEMAD VILLAGE, SURAT - 395 010

JAHANGIRPURA

TILES GALLERY

BLOCK NO. 34-35, OPP SIKHAR AVENUE,
BESIDE JAHANGIRPURA CHECK POST
JAHANGIRPURA, SURAT - 395005

www.vincore.in

☎ +91 94281 49001 / +91 97144 49002

✉ sales@vincore.in 🌐 www.vincore.in

Follow Us On  



VINCORE[®]

Aluminium Window System



Silent Motion,
Bold Vision

www.vincore.in



OVER 15 YEARS EXPERIENCE IN INDUSTRY

Vincore is a leading provider of high-quality aluminum window systems in India. With a strong commitment to innovation and customer satisfaction, we offer a wide range of products designed to enhance the beauty and functionality of your space. Our state-of-the-art manufacturing facilities and skilled workforce ensure that every product meets the highest standards of quality and durability.





vision

Our vision at Vincore is to be the leading provider of premium aluminum window systems, known for our commitment to excellence, innovation, and sustainability. We strive to set new benchmarks in the industry and to exceed the expectations of our customers, partners, and stakeholders.

mission

Our mission at Vincore is to provide the highest quality aluminum window systems that exceed industry standards for durability, sustainability, and performance. We are committed to delivering innovative solutions that enhance the aesthetics and functionality of modern buildings while ensuring customer satisfaction and environmental responsibility.

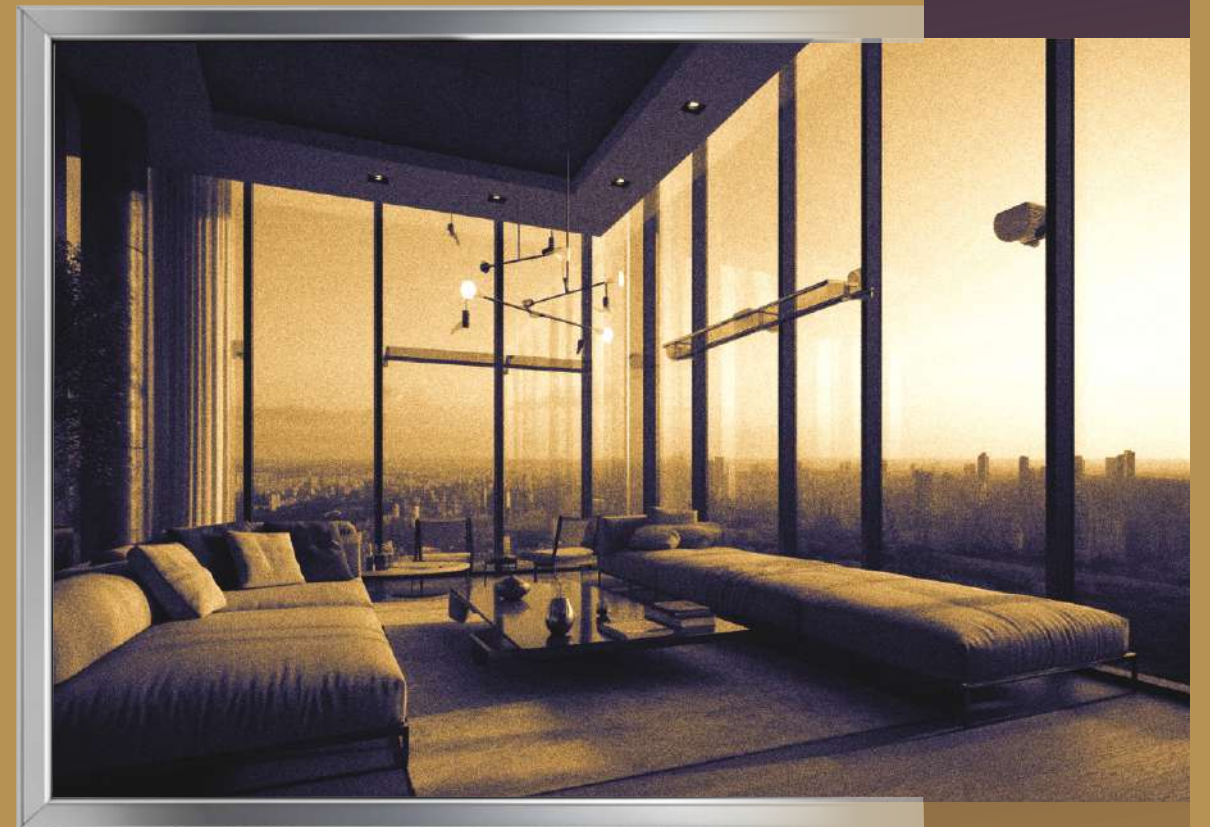



Why Choose Vincore?



Unmatched Quality:

Our windows are made with precision engineering and premium materials, ensuring durability and long-lasting performance.



Cutting-Edge Innovation:

We continuously strive to introduce innovative technologies and designs to meet the evolving needs of our customers.

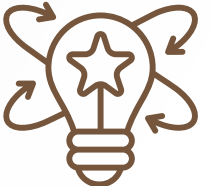

Design Flexibility:

Our wide range of styles, finishes, and customization options allows you to create windows that perfectly complement your architectural vision.



Sustainability:

We are committed to sustainable practices and offer energy-efficient solutions that reduce your carbon footprint.



Superior Performance:

Our wide range of styles, finishes, and customization options allows you to create windows that perfectly complement your architectural vision.

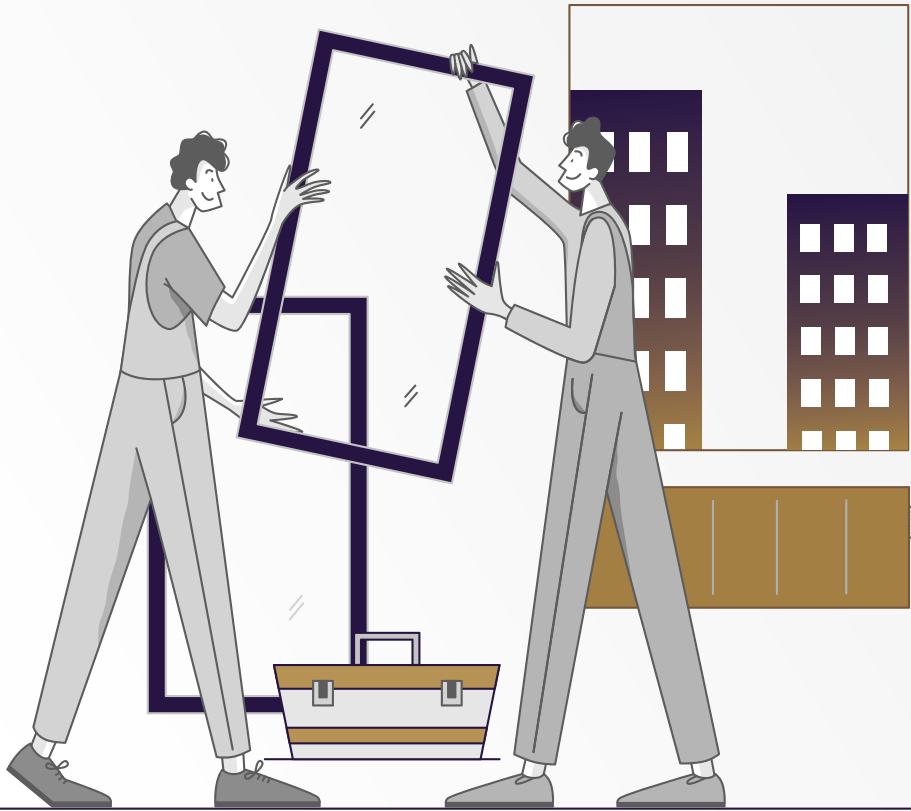



Sound
Insulation



Water
Resistant



Colour
Choice



Support

PROFILE ALLOY
6063

GLASS OPTIONS
5mm to 22mm

MAXIMUM SHUTTER HEIGHT
3600 mm

LOCKING POINT
Muliti

JOINTS
90 Degree

2 TRACK WIDTH
115 mm

INTERLOCK VISIBLE
19 mm

HARDWARE
Designed By VINCORE

MAXIMUM SHUTTER WIDTH
2100 mm

WIND LOAD
As Per Dimension

3 TRACK WIDTH
170 mm

TRACK BOTTAM HEIGHT
28 mm

Innovative Views,
Timeless Beauty.

VS Ultra Slim

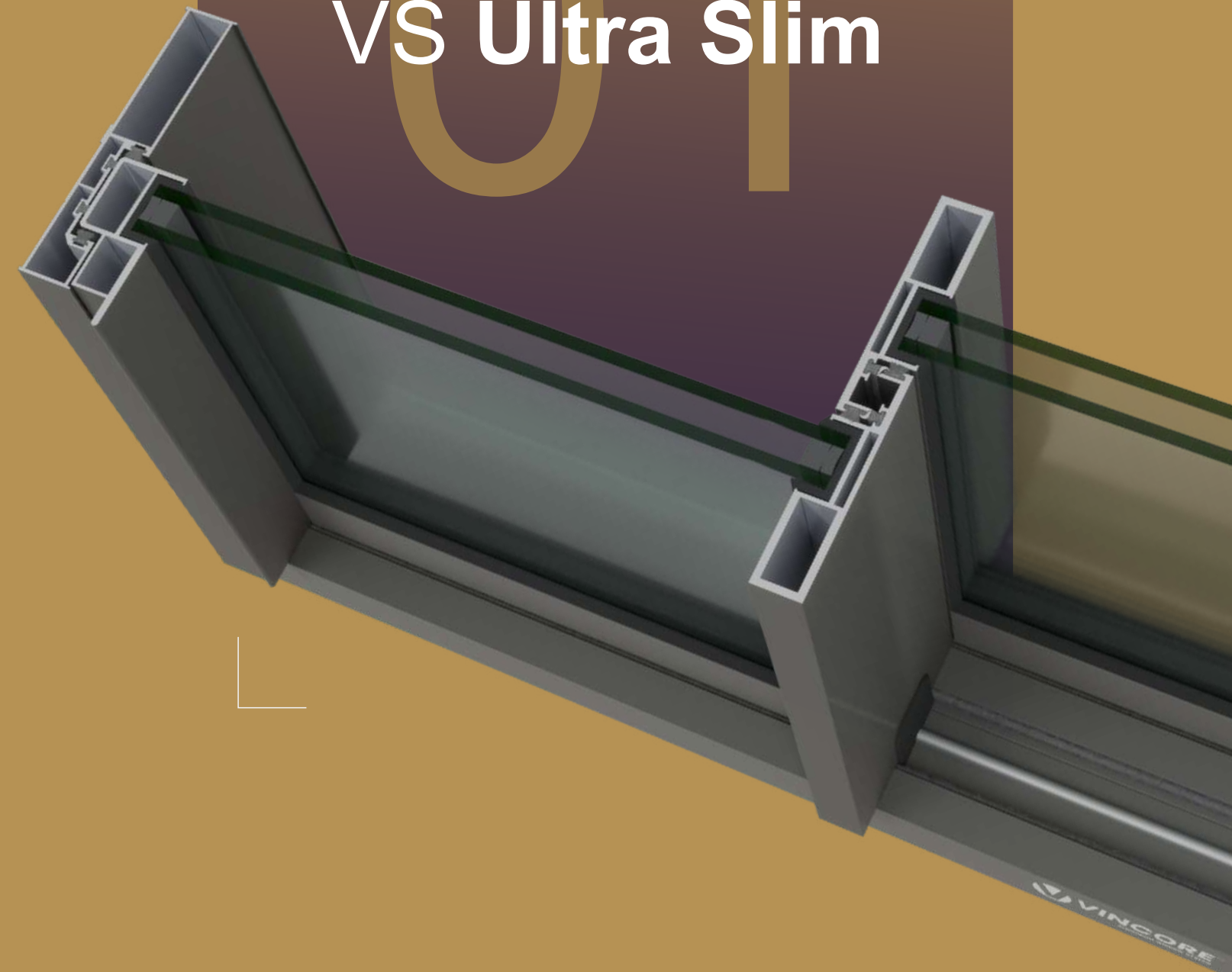

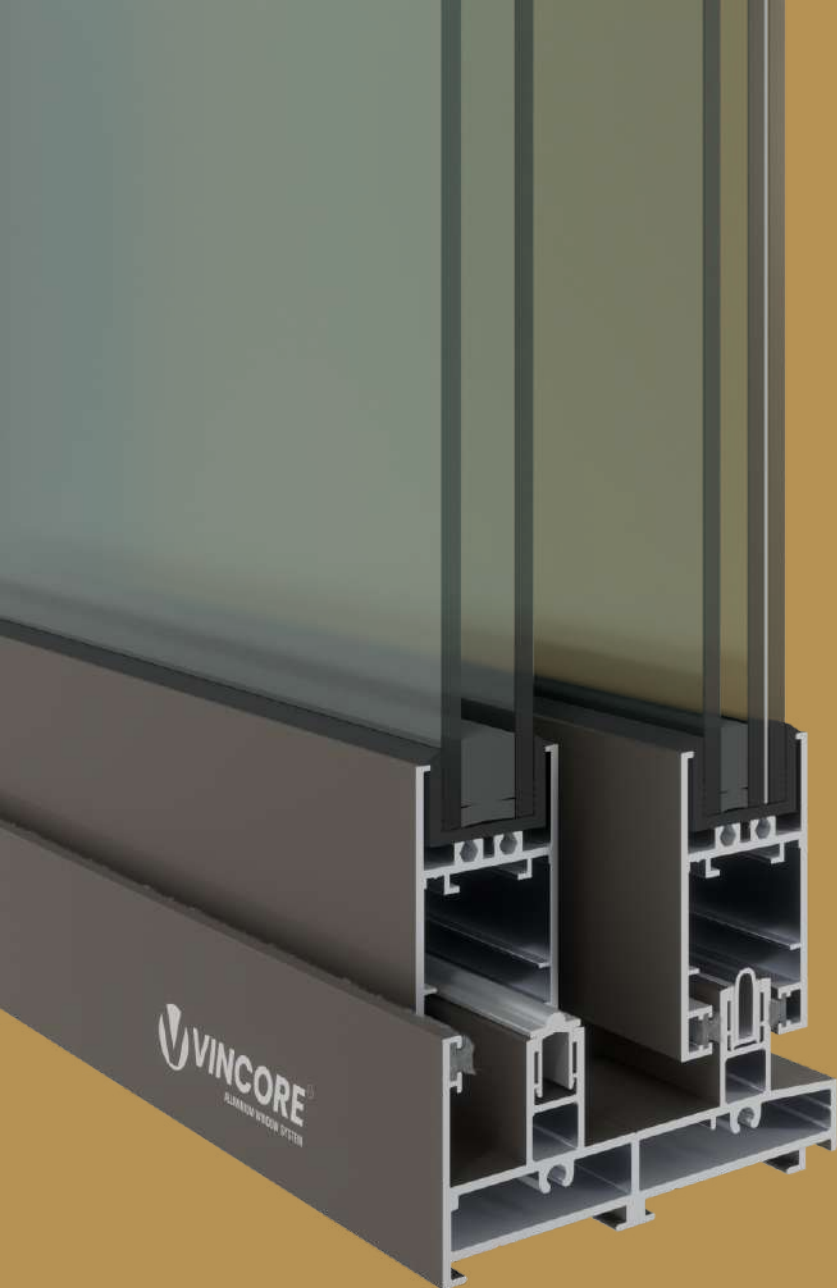

Sound
Insulation



Water
Resistant



Colour
Choice



Support

PROFILE ALLOY
6063

GLASS OPTIONS
5mm to 28mm

MAXIMUM SHUTTER HEIGHT
3900 mm

LOCKING POINT
Muliti

JOINTS
90 Degree

INTERLOCK VISIBLE
27 mm

HARDWARE
Designed By VINCORE

MAXIMUM SHUTTER WIDTH
2200 mm

CORNER WINDOW OPTION
Available

WIND LOAD
As Per Dimension

TRACK BOTTAM HEIGHT
50 mm

2 TRACK WIDTH
112 mm

3 TRACK WIDTH
162mm

Designed for Visionaries,
Built for Life.



VS Minimal Gulf

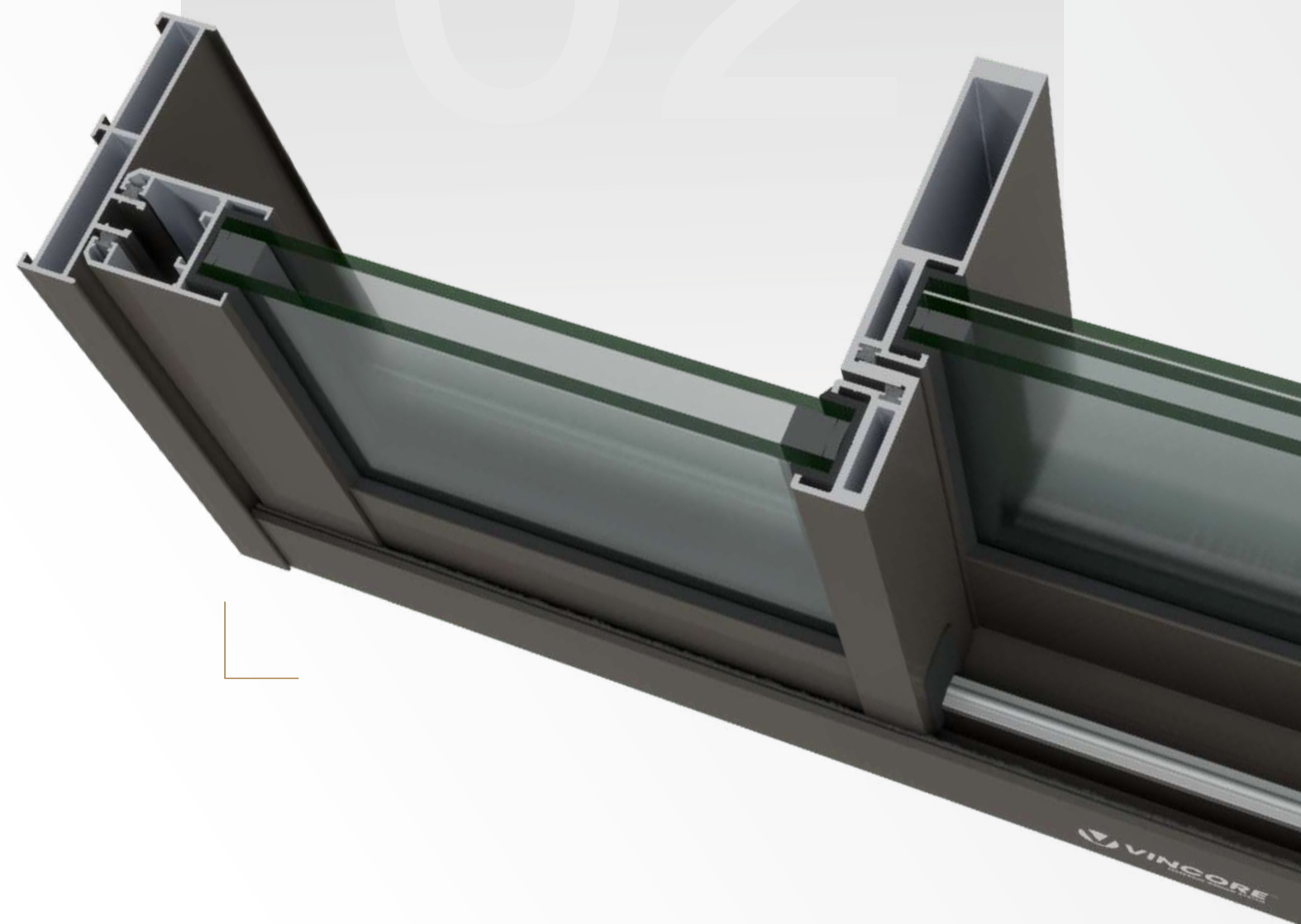



Sound
Insulation



Water
Resistant



Colour
Choice



Support

See Beyond.
Live Beyond.

VS 32 Gulf



PROFILE ALLOY

6063

GLASS OPTIONS

5mm to 20mm

MAXIMUM SHUTTER HEIGHT

2300 mm

LOCKING POINT

Single & Multi

INTERLOCK VISIBLE

22 mm

HARDWARE

Designed By VINCORE

MAXIMUM SHUTTER WIDTH

1400 mm

WIND LOAD

As Per Dimension

JOINTS

90 Degree

2 TRACK WIDTH

90 mm

3 TRACK WIDTH

135 mm

TRACK BOTTOM HEIGHT

40 mm

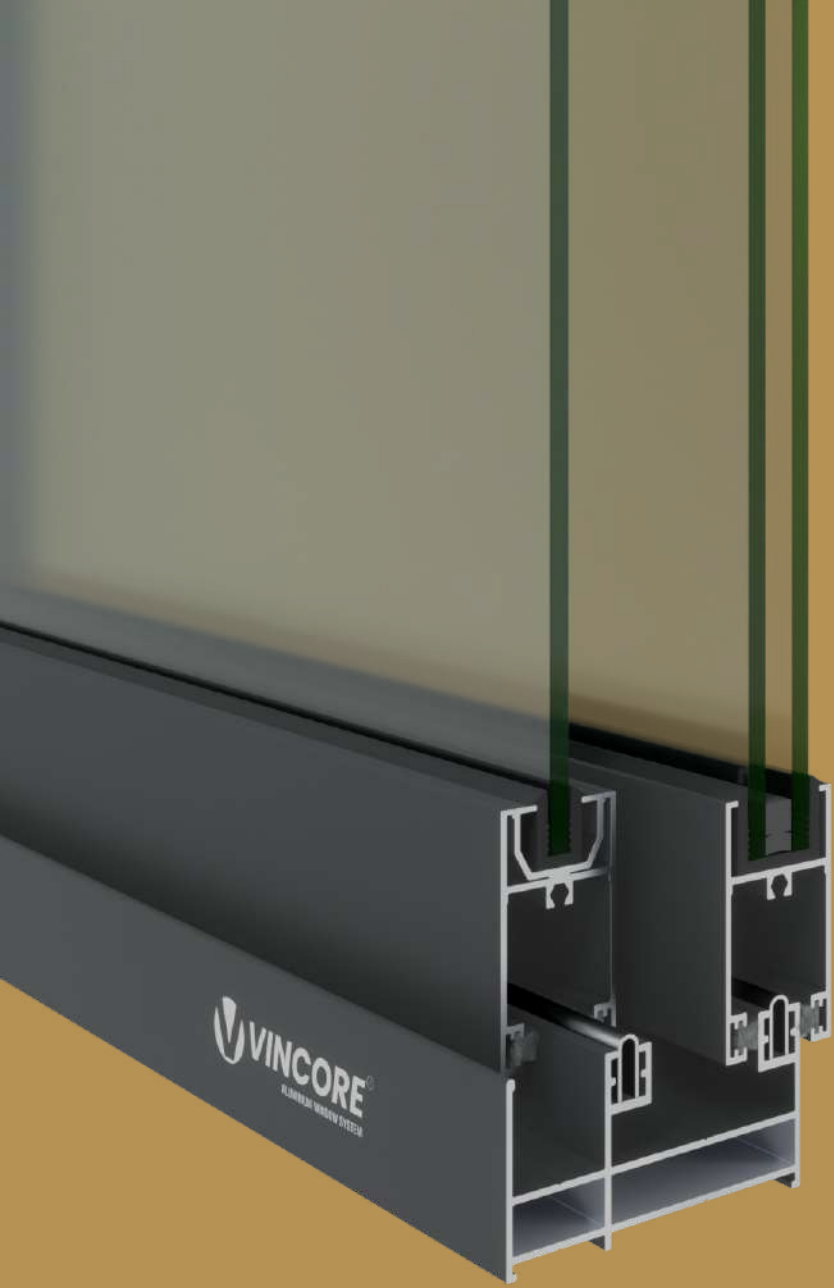

Sound
Insulation



Water
Resistant



Colour
Choice



Support

Luxury Framed
in Glass.



PROFILE ALLOY
6063

GLASS OPTIONS
5mm to 20mm

MAXIMUM SHUTTER HEIGHT
2800 mm

LOCKING POINT
Single & Multi

INTERLOCK VISIBLE
27 mm

HARDWARE
Designed By VINCORE

MAXIMUM SHUTTER WIDTH
1500 mm

WIND LOAD
As Per Dimension

JOINTS
90 Degree

2 TRACK WIDTH
80 mm

3 TRACK WIDTH
120 mm

TRACK BOTTAM HEIGHT
40 mm



Sound
Insulation



Water
Resistant



Colour
Choice



Support

PROFILE ALLOY
6063

GLASS OPTIONS
5mm to 20mm

MAXIMUM SHUTTER HEIGHT
2100 mm

LOCKING POINT
Single & Multi

JOINTS
45 Degree

INTERLOCK VISIBLE
21 mm

HARDWARE
Designed By VINCORE

MAXIMUM SHUTTER WIDTH
1200 mm

MOSQUITO MESH SOLUTION
Yes

WIND LOAD
As Per Dimension

TRACK BOTTOM HEIGHT
40 mm

2 TRACK WIDTH
70 mm

3 TRACK WIDTH
110 mm

Smart Windows
for Smart Living

VS 27

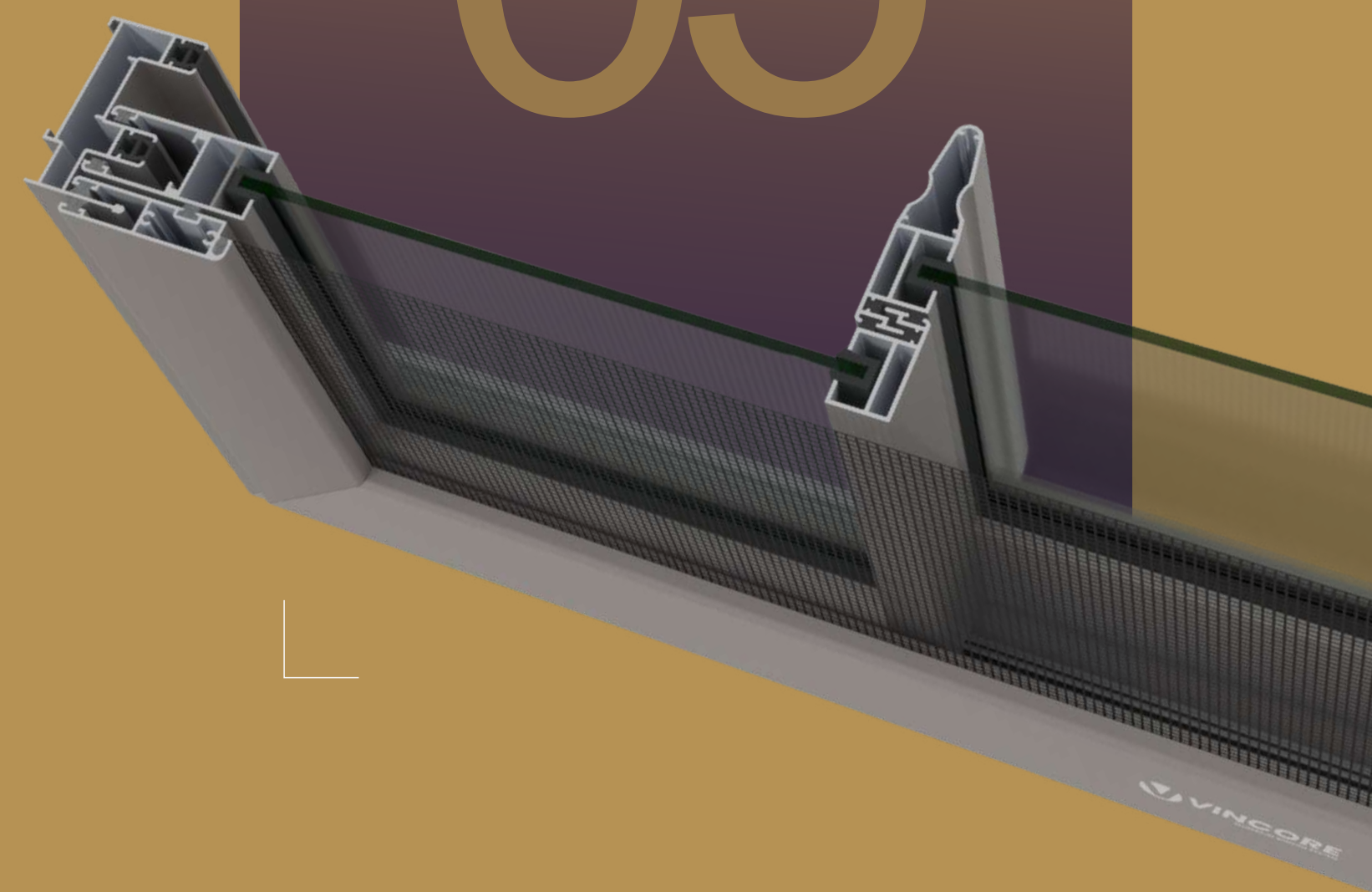



Sound
Insulation



Water
Resistant



Colour
Choice



Support

PROFILE ALLOY
6063

SIGHT LINE
40 mm

GLASS OPTIONS
5mm to 20mm

HARDWARE
Designed By VINCORE

MAXIMUM SHUTTER HEIGHT
1900 mm

MAXIMUM SHUTTER WIDTH
900 mm

LOCKING POINT
Single & Multi

WIND LOAD
As Per Dimension

JOINTS
45 Degree

Simplicity in
Every View

VS Casement



VS RAILING SYSTEM



Silvercoin is focused and committed to manufacturing the most robust railing systems in the market. Our product range is demanded in the market for their salient features like sturdy construction, attractive designs and durability. We are known for our supreme quality, versatility and extravagant look

With the prime focus on customer satisfaction, we strive hard to surpass client expectations with sound technical and management services. We seek to blend innovation and technology to create a secured home space.

The expertise & industrial exposure of our team facilitates accurate and flawless production. We are committed to give superior products with admirable designs and precision.

FEATURES



Easy to Install



Finest Quality



Aesthetic Designs



Competitively Priced



Hi-Grade Raw Materials

WHY US?



Timely Delivery & Installation



Complete Interior



Quality Oriented Approach



Talented Workforce

Premium Stair Railings Elevate Your Space with Elegance & Strength

At VINCORE, we bring you a collection of high-quality stair railings that seamlessly blend style, durability, and safety. Designed for both residential and commercial spaces, our stair railings are crafted with precision, ensuring unmatched aesthetics and functionality.

VS STAIR RAILINGS

Why Choose Our Stair Railings?

Superior Quality Materials :

Available in stainless steel, glass, wrought iron, wood, and brass for lasting durability.

Elegant & Customizable Designs :

Choose from classic, modern, and artistic styles to match your interior.

Safety & Strength :

Engineered for maximum support and stability, ensuring safety without compromising style.

Weather & Corrosion Resistant :

Perfect for indoor and outdoor applications with premium coatings and finishes.

Easy Installation & Low Maintenance :

Designed for hassle-free setup and long-lasting performance.

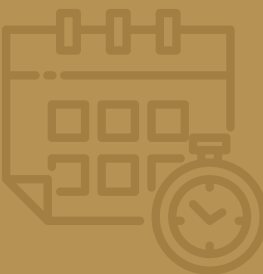



VS Lovers System

Introducing our premium exterior opening system, designed for exceptional thermal efficiency and acoustic insulation, adapting seamlessly to any climate. This versatile modular system boasts innovative fixed adjustable louvers with integrated mosquito nets, offering a choice of openable and sliding window styles, including a unique 50mm openable window option and a cutting-edge sliding system with adjustable louvers. Perfect for both residential (homes, apartments) and commercial applications (offices, hotels, airports, industrial constructions), our system delivers superior energy efficiency, low maintenance, and a lightweight, high-strength design, all while being 100% recyclable and customizable with a wide range of RAL colors and wood finishes. Proudly made in India.

Benefits:

- Environmentally Friendly:
100% recyclable materials
- Energy Efficient:
Reduced heating and cooling costs
- Low Maintenance:
Resistant to corrosion and rust
- Lightweight & High Strength:
Optimal structural integrity
- Customizable Finishes:
Wide range of RAL colors and wood grain options

PROFILE ALLOY

6063

ALUMINIUM LOVERS

MAXIMUM SHUTTER HEIGHT

1500 mm

LOCKING POINT

Muliti

JOINTS

45 Degree

HARDWARE

Designed By VINCORE

MAXIMUM SHUTTER WIDTH

700 mm

WIND LOAD

As Per Dimension

Applications:

- Residential Homes and Apartments
- Commercial Offices, Hotels, Airports
- Industrial Constructions

Split Sliding Partitions

Telescopic | Synchronized | One way slide door

Features and Benefits

- 16 mm minimalistic partition
- Colour of profile can be customized
- Glass thickness is 8 mm standard
- Grid profiles can be added as per choice
- Glass types fabric, fluted any of the choice
- Soft closing and opening of shutter
- Doors can be pocket inside walls

Synchronize Partition System & Telescopic Partition System Features:

- Two way soft close & one way soft close
- Aluminium Profile suitable for 8mm glass
- Available with lock option I key lock option
- Can use Stick on grid or Integrated grid for enhancing the design

VS PARTITION SYSTEM

Synchronize 2+2



Telescopic 1+1



Telescopic 2+1



Telescopic 3+1

